

Octagonal CUPOLA
screened with louvers
and light fixture

MODULAR GAZEBO KIT
SERIES GARDENHOUSE 12'
with SINGLE-TIERED Roof

Lumber:
Western Red CEDAR #1 (Cabinet)
Shingles:
5X / 16" long / 1/2" thick
or 16 oz. copper
over 5/8" T/G

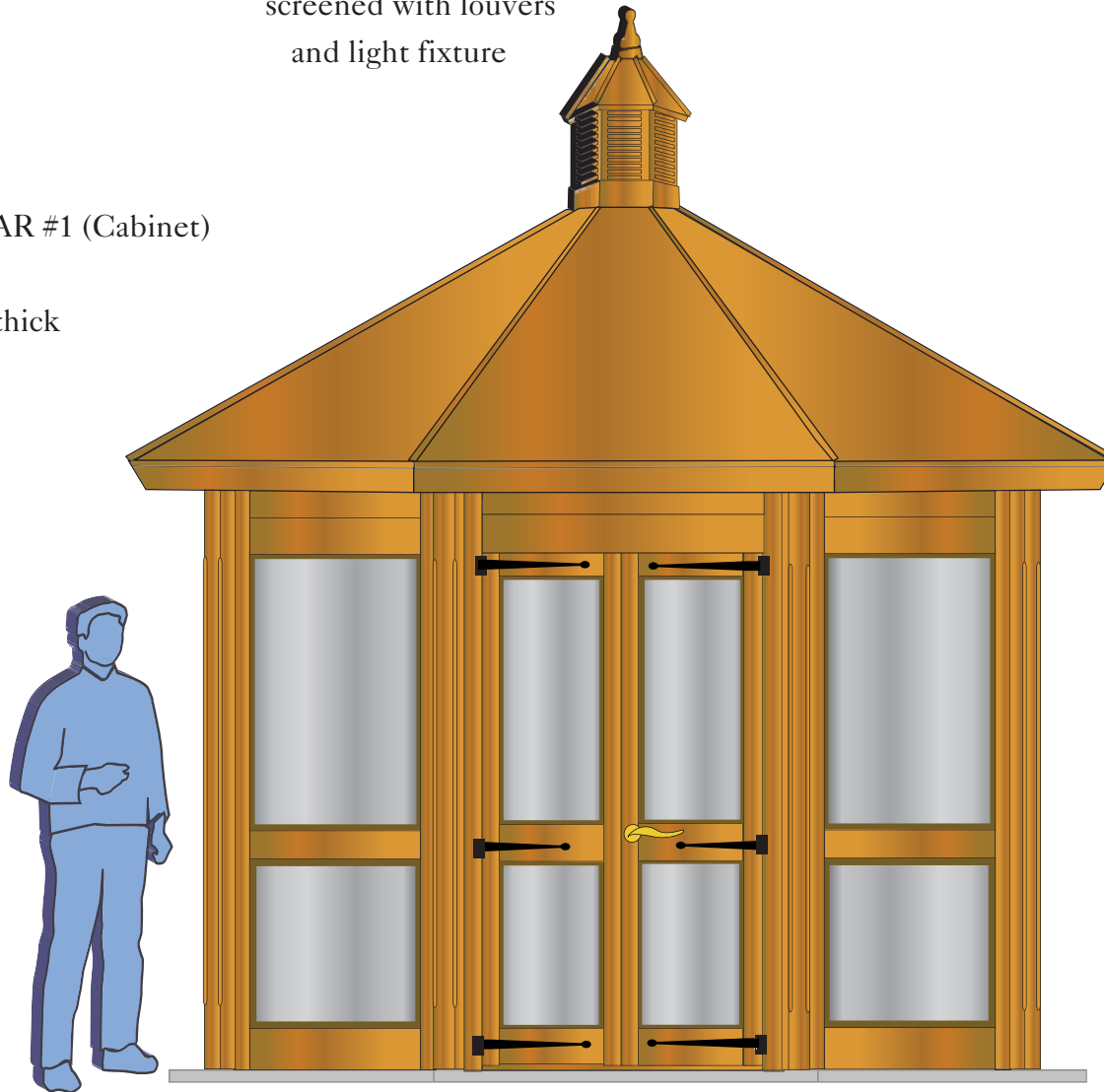

Removable Screens
Interchangable &
Enclosure Inserts

Entry Key Lock Set
(bright brass or dark bronze)

Without Cedar Floor



**VIXEN HILL CEDAR
PRODUCTS**

P.O.Box 389 - Elverson, PA 19520
800-423-2766

Created by: Andrea Beringer

Date: Jan 2015

Drawing: 1 of 9

Model: 12'

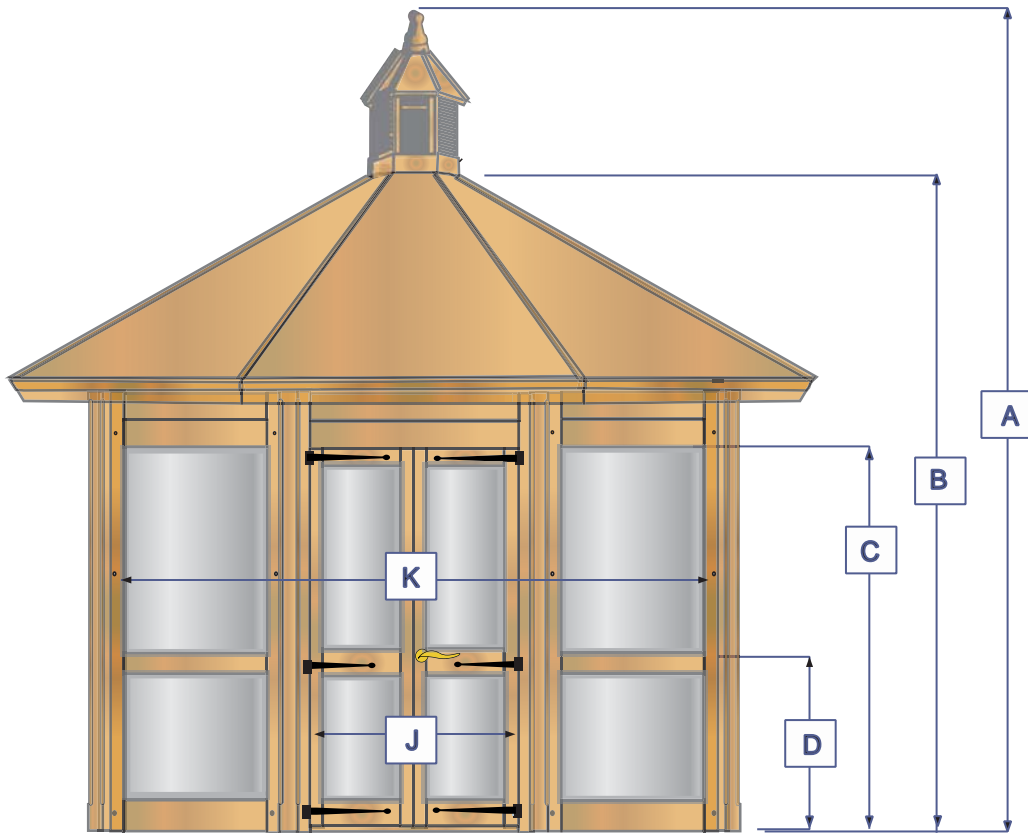

SIZE & DIMENSIONS

Key: Based on roof type	12A
*A: Height, Overall	154"
B: Height, Grade/peak	125"
C: Height, Door	80 1/4"
D: Height, Top of Cross-Rail	34"
J: Width, Door Entrance	36"
K: Width, Interior Min.	116"



**VIXEN HILL CEDAR
PRODUCTS**

P.O.Box 389 - Elverson, PA 19520
800-423-2766

Created by: Andrea Beringer

Date: Jan 2015

Drawing: 2 of 9

Model: GH-12A

WALL PANEL CONSTRUCTION

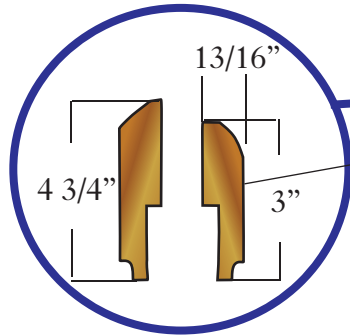

Inner Panel Cap
Outer Panel Cap



PLATED ROTO LOCK CONNECTS WALL PANEL TO POST.

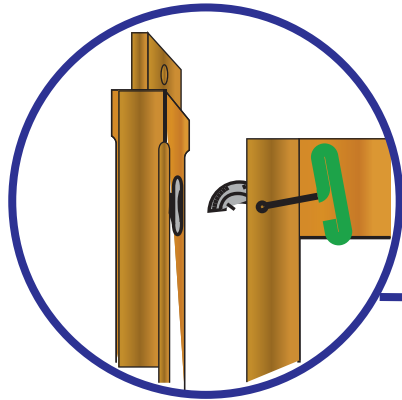

4X4 Post

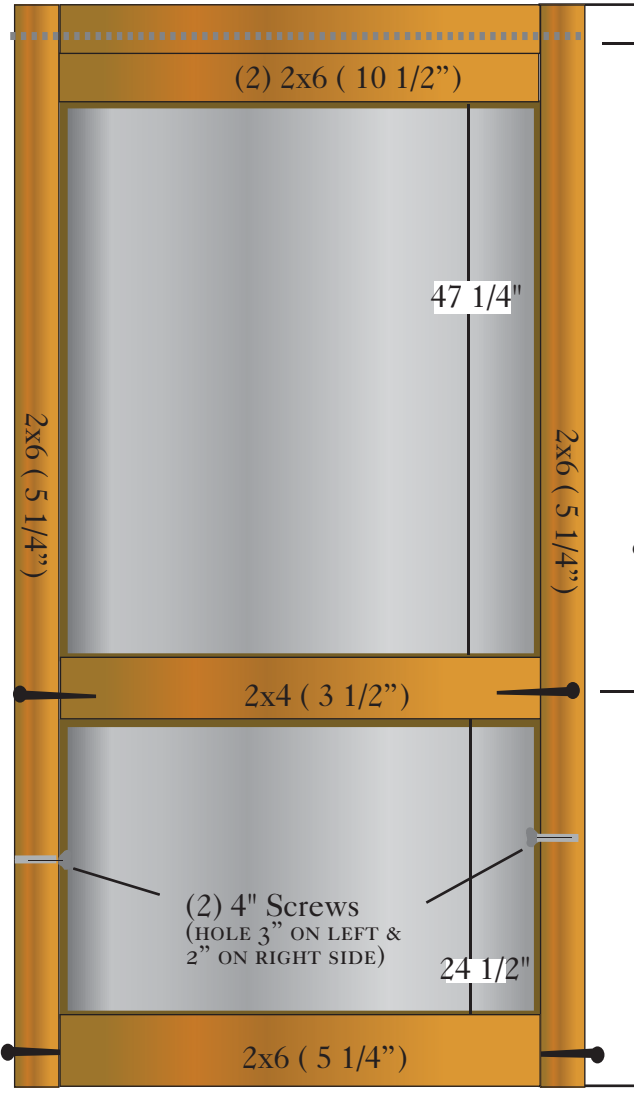

Threaded-Through-Rod

(2) 2x6 (10 1/2")

47 1/4"

2x6 (5 1/4")

2x6 (5 1/4")

91"

2x4 (3 1/2")

6" Structural Screws

(2) 4" Screws
(HOLE 3" ON LEFT & 2" ON RIGHT SIDE)

24 1/2"

2x6 (5 1/4")

THRESHOLD

44 11/16"

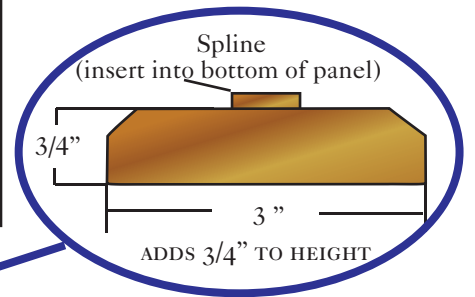

Spline
(insert into bottom of panel)

3/4"

3"

ADDS 3/4" TO HEIGHT

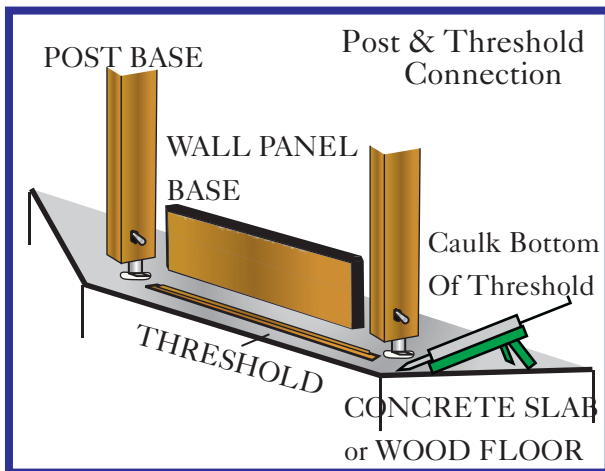

POST BASE

Post & Threshold Connection

WALL PANEL BASE

Caulk Bottom Of Threshold

THRESHOLD

CONCRETE SLAB or WOOD FLOOR



VIXEN HILL CEDAR PRODUCTS

P.O.Box 389 - Elverson, PA 19520
800-423-2766

Created by: Andrea Beringer

Date: Jan 2015

Drawing: 3 of 9

Model: GH-12

DOUBLE DOOR CONSTRUCTION

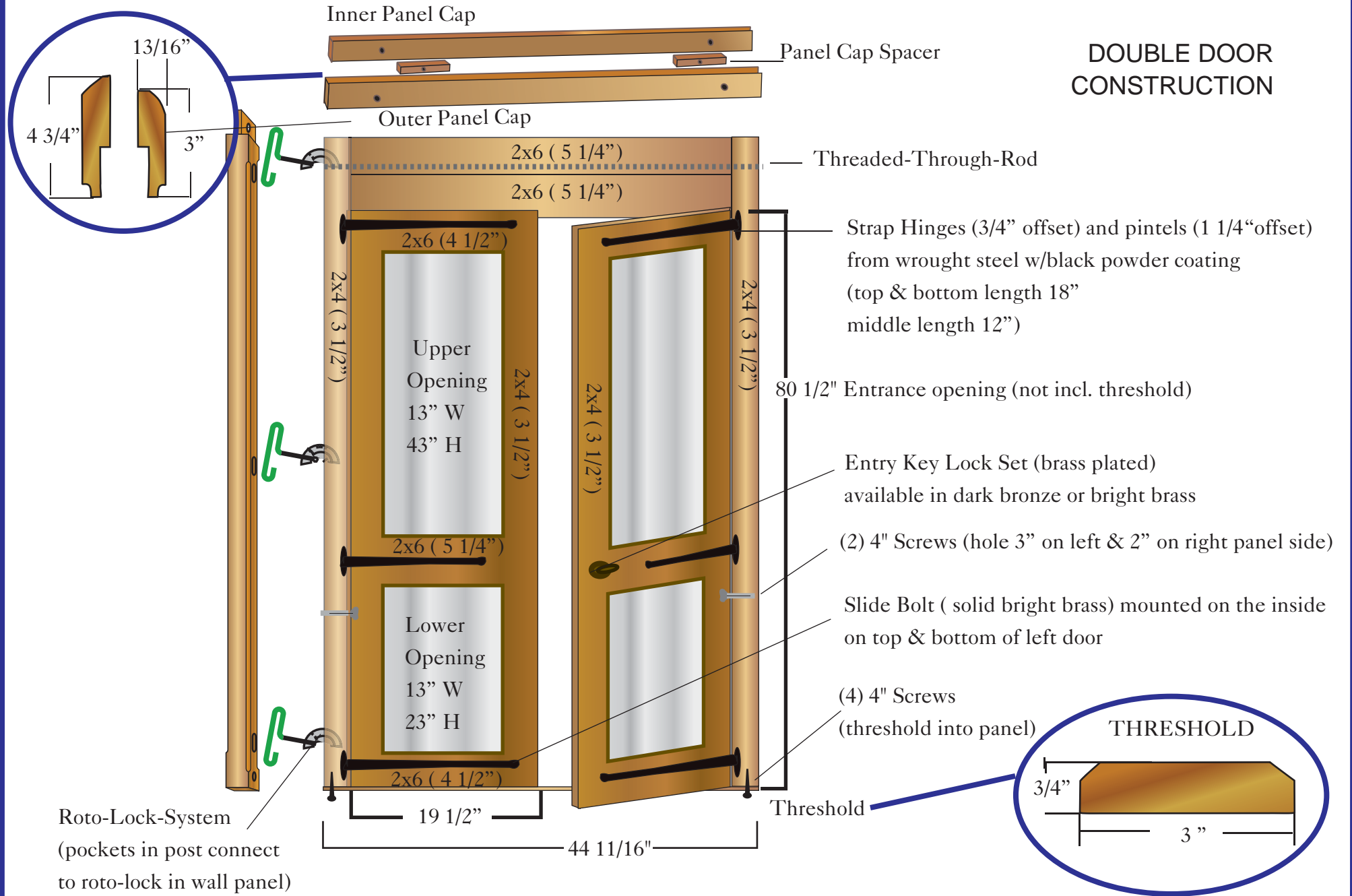

Electrical

**Light Fixture
(max. 500W)**

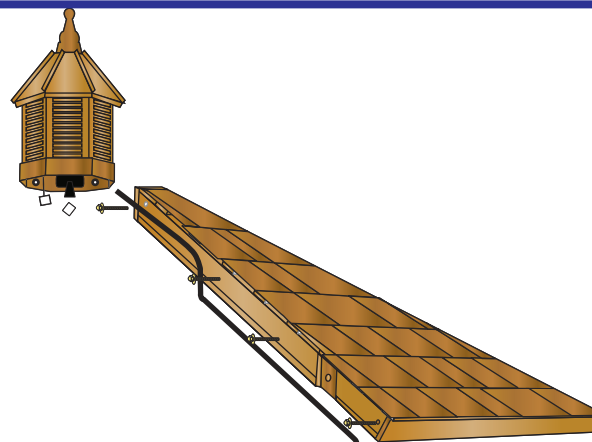

**One Pre-Wired Electrical Post
is standard for GH models**

Additional Options:

Outlet posts (dual)

Fan Control post (fan/light)

Channel Posts (for custom wiring)

14-2 UF/B with ground

**Hidden Wire
through
Channeled
Post**

**Electric Outlet
w/switch &
receptacle (GFI)**

**Floor Board
w/pre-drilled hole**

**Note: For concrete slab use conduit
through void (see slab instructions)**



**VIXEN HILL CEDAR
PRODUCTS**

*P.O.Box 389 - Elverson, PA 19520
800-423-2766*

Created by: Andrea Beringer

Date: Jan 2015

Drawing: 5 of 9
Model: GH

ROOF CONSTRUCTION

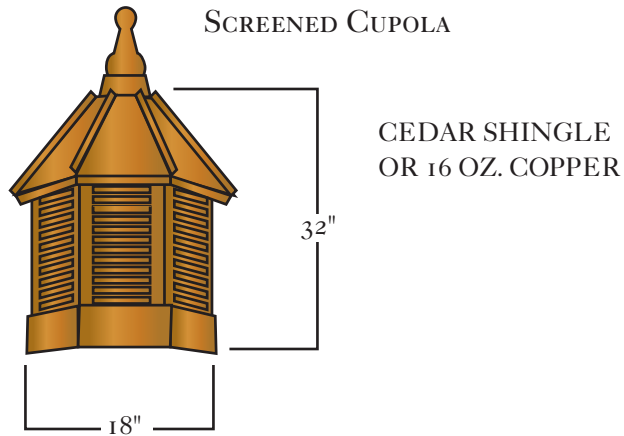

THE CUPOLA IS CONNECTED WITH STAINLESS STEEL SCREW FROM THE UNDER SIDE OF THE ROOF LATH.

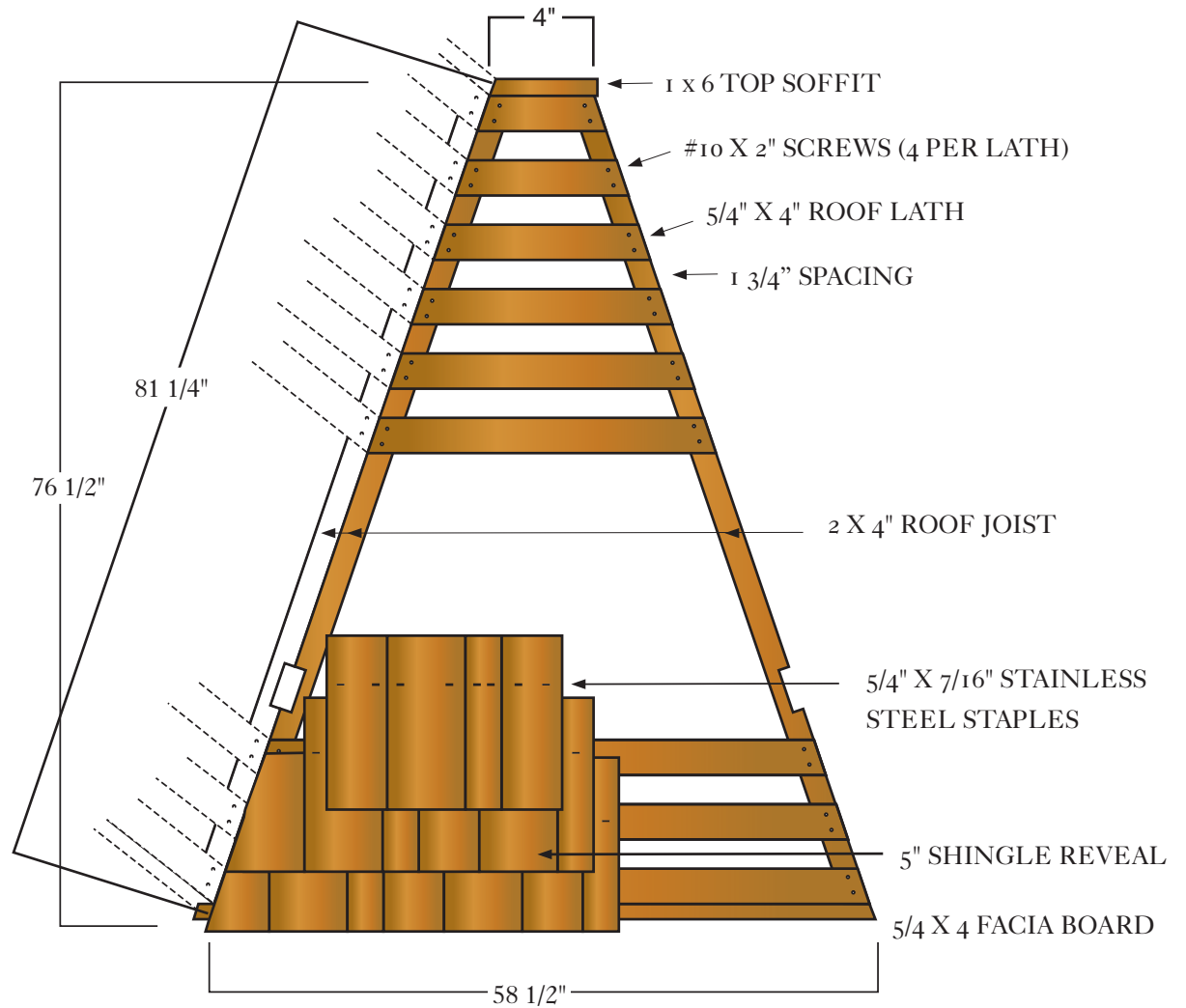

NOMINAL SIZES



VIXEN HILL CEDAR PRODUCTS

P.O.Box 389 - Elverson, PA 19520
800-423-2766

Created by: Andrea Beringer

Date: Jan 2015

Drawing: 6 of 9

Model: GH-12A

ROOF TO POST
MORTICE CONNECTION

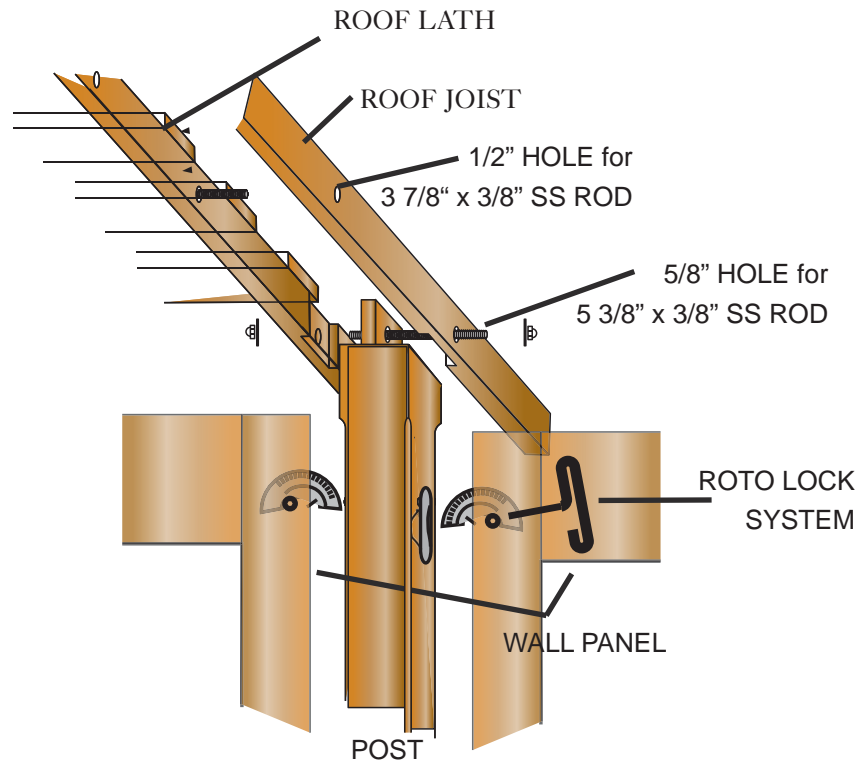

ROOF
ATTACHMENT

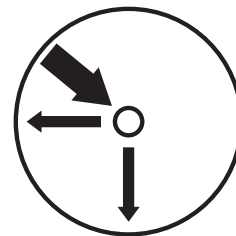
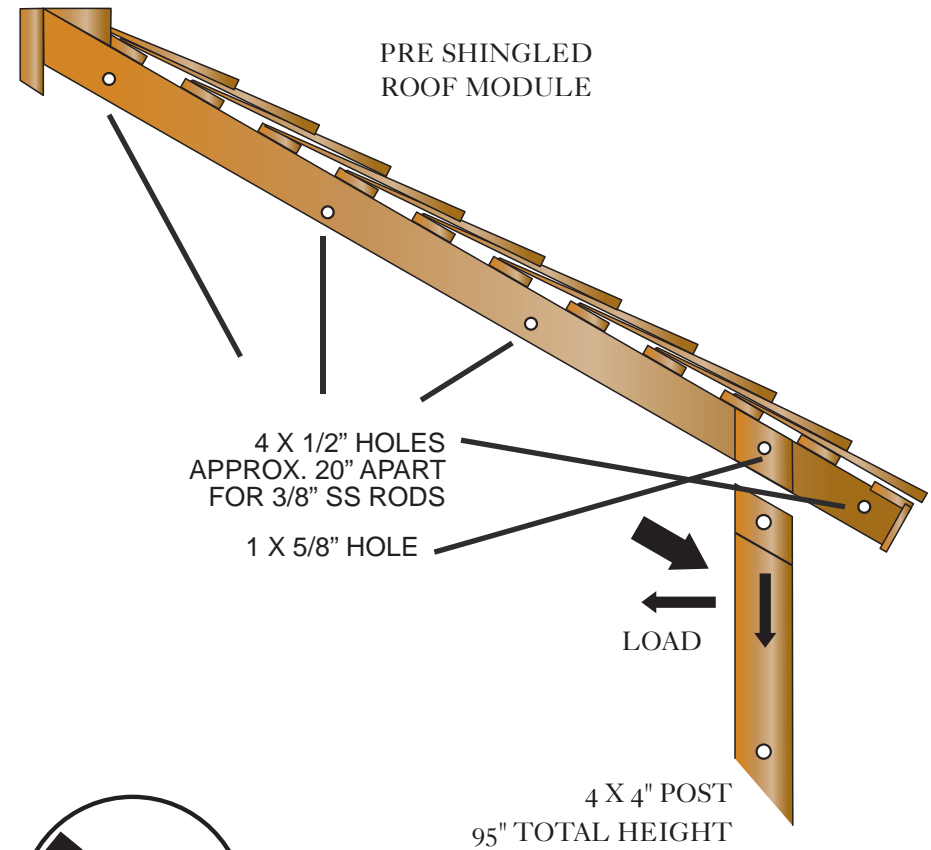

ROOF SYSTEM
RIDGED TRIANGULAR MODULES CONNECT TO FORM A CONIC ROOF SYSTEM. THE COMPRESSION RING IS INTEGRAL TO THE CONIC DESIGN AND ALLOWS RESULTANT FORCES TO BE PERPENDICULAR TO GRADE.



VIXEN HILL CEDAR PRODUCTS
P.O.Box 389 - Elverson, PA 19520
800-423-2766

Created by: Andrea Beringer

Date: Jan 2015

Drawing: 7 of 9
Model: GH-12A

CONCRETE SLAB Dimensions for UNITS WITHOUT FLOOR SYSTEM

ANCHORING HARDWARE DIMENSIONS

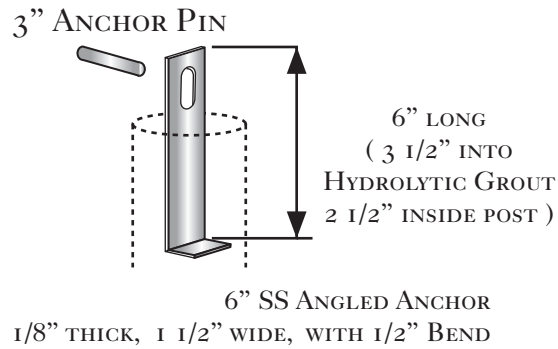

POST ANCHORING ON CONCRETE SLAB

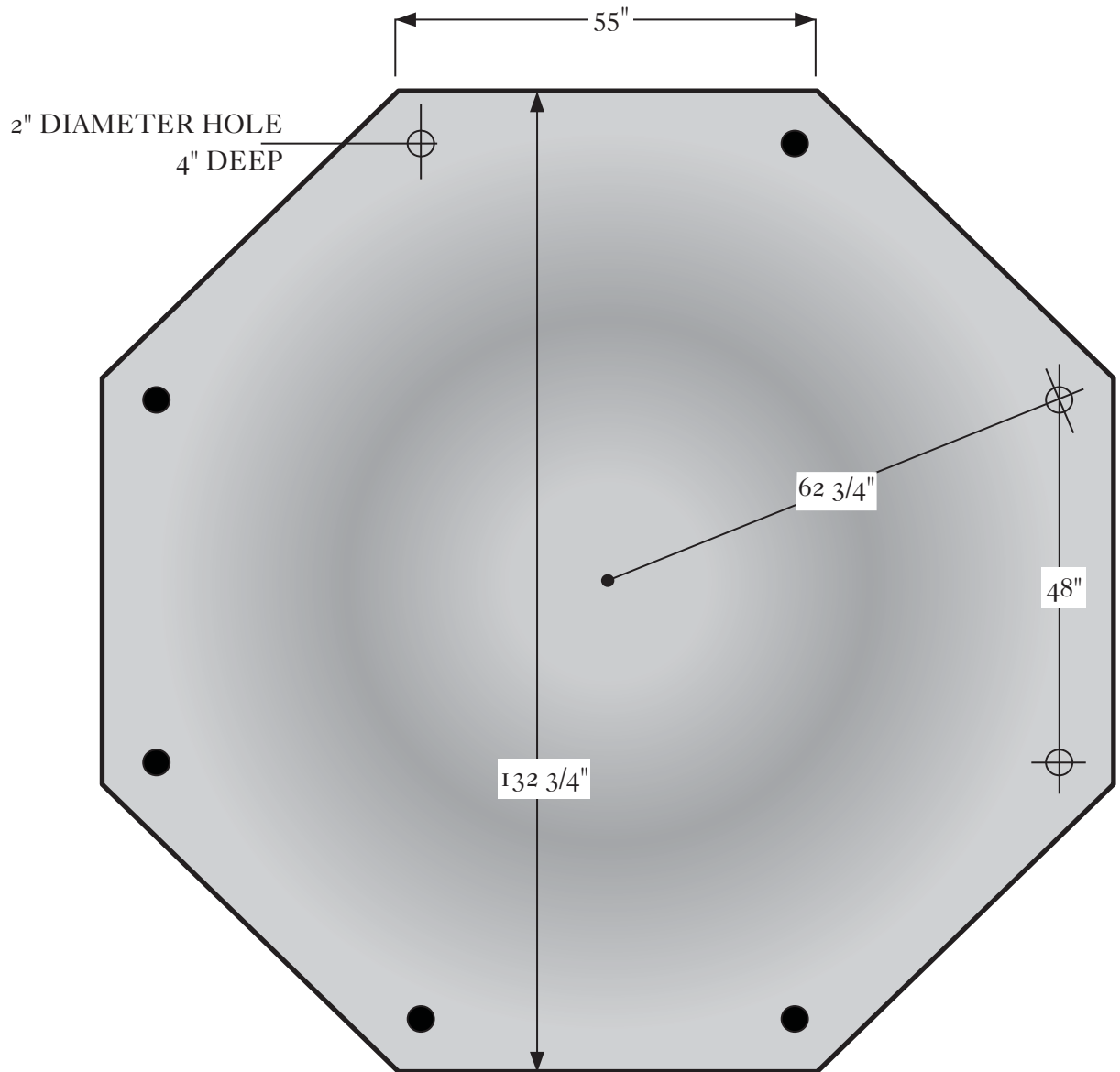
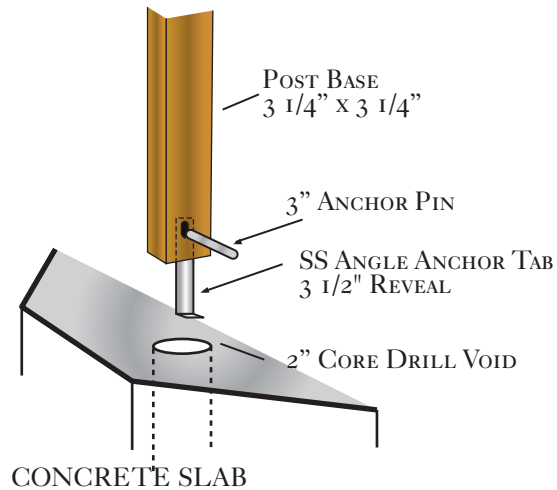

**VIXEN HILL CEDAR
PRODUCTS**

P.O.Box 389 - Elverson, PA 19520
800-423-2766

Created by: Andrea Beringer

Date: Jan 2015

Drawing: 9 of 9

Model: 12'

SPECIFICATIONS FOR THE CABINET MODELS (9', 12', 15', 8X11'X 11X15' AND 14X19', 22')

PART 1 GENERAL

1.1 SCOPE. THE CONTRACTOR SHALL FURNISH AND INSTALL A WOODEN GAZEBO AS SHOWN ON PLANS AND HEREIN SPECIFIED AS SUPPLIED BY VIXEN HILL MFG. CO. INC., OF ELVERSON, PA 19520.

PART 2 PRODUCT

2.1 WOOD MATERIALS. FOR CABINET GRADE SHALL BE FABRICATED FROM AIR-DRIED, #1 OLD GROWTH & ROT RESISTANT WESTERN RED CEDAR. ALL WOOD SHALL BE GRAIN SELECTED DURING IN-HOUSE MILLING FOR BEST APPLICATION AND SAFE USE.

2.2 ROOFING SYSTEM. SHINGLES SHALL BE OF OR EQUAL TO #1 PERFECTION CLEAR HEART CEDAR AND PER THE FOLLOWING SPECIFICATIONS 5X, 16" LONG, 1/2" THICK, TAPERED. ROOF LATH SHALL BE OF NO LESS THAN NET FINISHED SIZE 1X3" WITH A 5" SPACING. ROOF SECTIONS SHALL BE COMPLETELY PRE-ASSEMBLED AND PRE-CUT, AND JOINTS BETWEEN ROOF SECTIONS SHALL BE SELF-SEALING TO PRECLUDE CAPPING. CAULK IS RECOMMENDED TO BE USED AT THE ROOF JOIST.

2.3 SURFACE FINISH. ALL WOOD MEMBERS SHALL BE SURFACED FOUR SIDES. SURFACES DISPLAYING PLANER SKIPS OR SAW MARKS AFTER DRESSING SHALL BE LIMITED TO LESS THAN 25% OF SHOWN FACES. HAND CONTACT EDGES MAY BE ROUNDED, CHAMFERED, OR EDGE-SHAPED FREE OF SPLINTERS AND SMOOTH TO THE TOUCH. ALL EXPOSED SURFACES SHALL BE PREPARED FOR MAXIMUM ACCEPTANCE OF OIL-BASED FINISHES (OPTIONAL WITH ADDITIONAL COST).

2.4 HARDWARE. ALL ASSEMBLY & ANCHORING HARDWARE SHALL BE PROVIDED. CONCEALED ROTO-LOCKS ARE BUILT INTO THE WALL PANEL. THE THREADED RODS FOR THE PANEL CAPPING PIECES ARE OF GALVANIZED STEEL WITH STAINLESS STEEL CAP NUTS & WASHERS AND OF A FINISH TYPE TO CONCEAL ALL THREADS. ALL HARDWARE IN GROUND CONTACT SHALL BE OF STAINLESS STEEL FOR CABINET GRADE. NO NAILS SHALL BE REQUIRED OR PROVIDED. THE STRAP HINGES FOR THE DOOR(S) ARE MADE FROM ZINC-PLATED & POWDER-COATED STEEL WITH A FLAT AND SMOOTH FINISH.

2.5 ELECTRICAL. STANDARD FOR CABINET GRADE. THE PRE-WIRED POST PROVIDES 110V ELECTRICAL SERVICE THROUGH WIRE (14-2 UF/B WITH GROUND). THE POST HAS AN ELECTRICAL BOX WITH (GFI) RECEPTACLE AND LIGHT SWITCH. THE LIGHT FIXTURE IS SCREWED INSIDE THE CUPOLA FOR UP TO 500W STRENGTH. WIRES SHALL BE HIDDEN WITHIN THE COMPONENT PARTS THROUGH GROOVED ROOF SECTION AND CHanneled POST. ALL ELECTRICAL COMPONENTS SHALL BE UL APPROVED.

2.6 CONNECTIONS & ANCHORING. FACTORY MODULE CONSTRUCTION SHALL INCLUDE POCKET JOINTS AND STAINLESS STEEL THREADED FASTENERS. ON-SITE INTER-CONNECTION OF MODULES SHALL BE ACHIEVED USING THREADED RODS AND STAINLESS OR BRASS CAP NUTS AND WASHERS. ANCHORING SHALL BE CONCEALED AND APPROPRIATE TO THE SURFACE MOUNTING MATERIAL. ONLY SIMPLE HAND TOOLS SHALL BE REQUIRED FOR ASSEMBLY.

2.7 ENGINEERING. DESIGN OF CONNECTIONS AND MATERIALS USED SHALL BE SUCH AS TO ADHERE TO STRUCTURAL REQUIREMENTS OF MAJOR BUILDING CODES. DRAWINGS AND REPRESENTATIVE ENGINEERING SHALL BE AVAILABLE FROM THE MANUFACTURER FOR THE PURPOSE OF PERMITS OR ARCHITECTURAL REVIEW.

PART 3 EXECUTION

3.1 PREFABRICATION. ALL COMPONENT PARTS SHALL BE PRE-ASSEMBLED TO THE FULLEST EXTENT POSSIBLE, TO PRECLUDE ANY ON-SITE DRILLING, CUTTING, FILLING, NAILING OR SANDING. ALL PREFABRICATION FASTENERS SHALL BE HIDDEN FROM VIEW OR CHanneled AND STRIPPED WITH MATCHING WOOD WHERE VISIBLE.

3.2 INSTALLATION. THE GAZEBO KIT SHALL BE SUPPLIED WITH ALL NECESSARY HARDWARE, SHOP DRAWINGS AND COMPLETE INSTRUCTIONS TO PROVIDE FOR EFFICIENT ON-SITE ASSEMBLY. AVERAGE ASSEMBLY TIME ON A PREPARED FOUNDATION SHALL NOT EXCEED 15 MAN-HOURS.



**VIXEN HILL CEDAR
PRODUCTS**

P.O. Box 389 - Elverson, PA 19520
800-423-2766

Created by: Andrea Beringer

Date: Jan 2015

Drawing: 9 of 9

Model: GH