

DOUBLE OCTAGONAL CUPOLA
26" x 80"

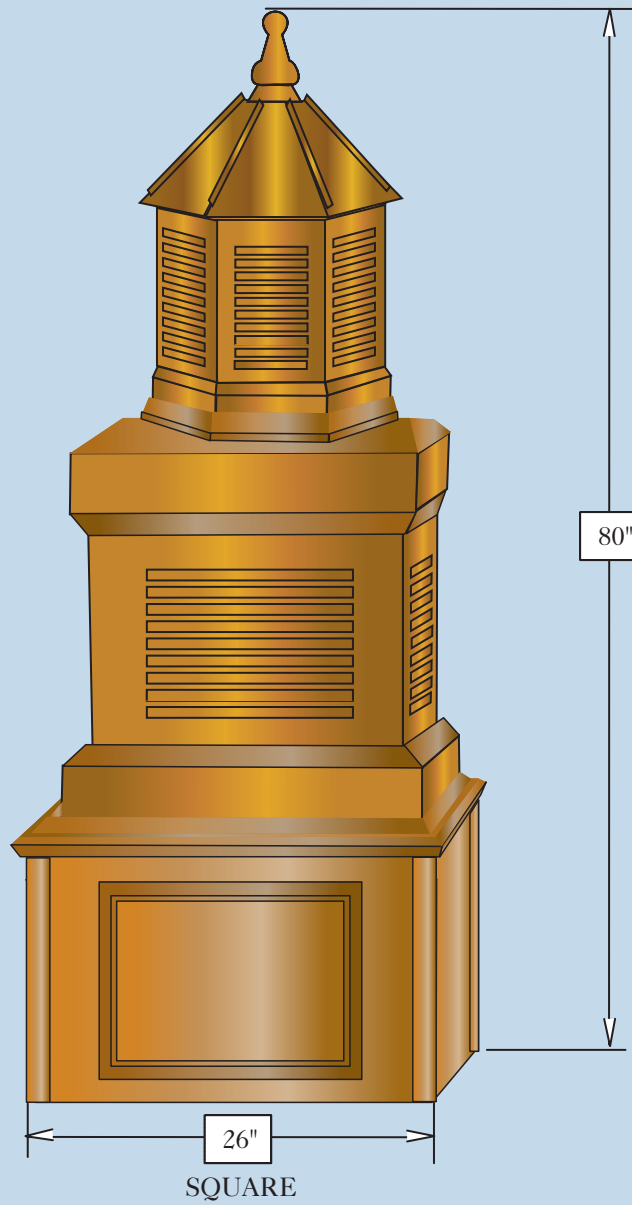

Vixen Hill
Manufacturing Company

Main Street
Elverson Pa. [19520]
Phone: 610-286-0909
Fax 610-286-2099

SHEET TITLE: Double Cupola

DRAWN BY: Andrea Beringer

Date: 09-2007

DRAWING NO: 001 MODEL: 26" x 80"

PROJECT: Cupola Structural System

Western Red Cedar SADDLE BOX,
BASE & BODY

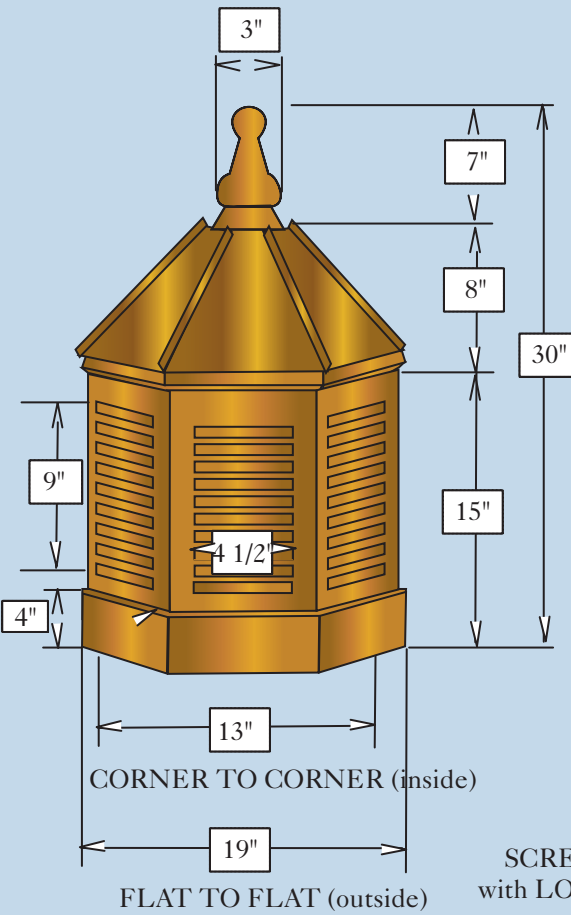

Finial or Weathervane
attach to 3/4" threaded bolt

Wester Red Cedar SHINGLES
or 16oz. Copper Roof

SCREENED Opening
with LOUVERS

Lower Molding
Tickness 1 1/2"

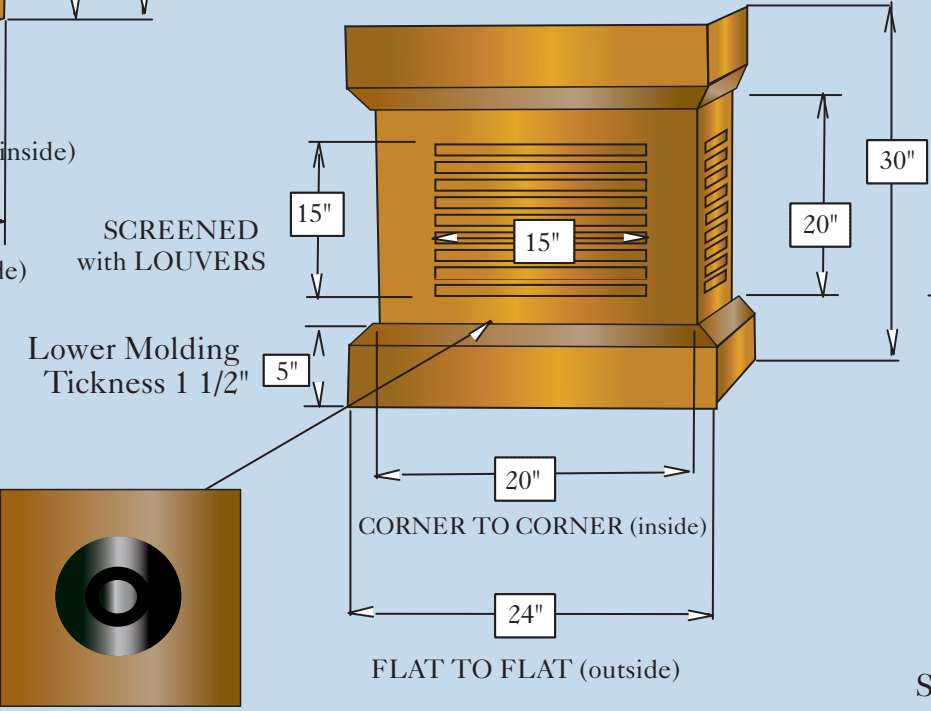

SCREENED
with LOUVERS

Lower Molding
Tickness 1 1/2"

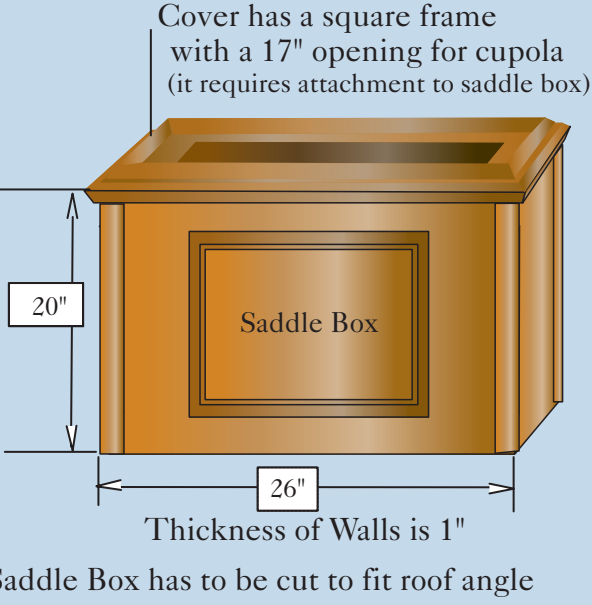

Cover has a square frame
with a 17" opening for cupola
(it requires attachment to saddle box)

Thickness of Walls is 1"
Saddle Box has to be cut to fit roof angle

LIGHT FIXTURE
in bottom of cupola

